

INSTRUCTION MANUAL – AIR DRIVEN HYDROTEST PUMPS:

Model Series: AHP10, AHP26, AHP36, AHP58, AHP107, AHP187, AHP275, AHP425, AHP2-036, AHP2-060, AHP2-097, AHP2-144, AHP2-237, AHP3-040, AHP3-060, AHP3-100, ATDP63, ATDP125, ATDP216,

1.0 Inspection of the product upon receipt:

On receipt of the product, visually inspect the item for any evidence of shipping damage. Please note shipping damage is not covered by warranty. If shipping damage is found notify the carrier immediately and refrain from putting the product into service. The carrier is responsible for repair and replacement costs resulting from damage in transit shipment.

2.0 Safety Precautions:





Read and follow all the instructions and safety warnings carefully prior to use of the equipment. Failure to do so could result in equipment damage or failure of the equipment or personal injury. Hi-Force will not be held responsible for any damage to the equipment or personal injury resulting from unsafe use of the product, lack of maintenance or incorrect operation. If in doubt on the correct usage of any Hi-Force equipment, contact your nearest Hi-Force office or distributor. If the operator has not been trained on high pressure hydraulic equipment and its safe use consult your local Hi-Force sales office who can offer you training courses for operators.



All operators should ensure that all necessary personal protective equipment as specified by their employer is worn when operating any hydraulic equipment. Safety shoes, safety glasses/ visor and protective gloves should be worn at all times. All relevant risk assessments should be completed prior to use of the equipment.

 **Warning:** All ancillary equipment to be used with these ranges of Hydrotest pumps **MUST** be rated for use at the same operating pressure as the pump model to be used:

 Sufficient time should be allocated to planning your hydraulic system. Make sure that all the components are fit for the intended use

 **DO NOT** exceed the rated pressure of the pump or the rated capacity of the system to be used.

AHP SERIES – Hydrotest Pumps:

1.0 General Description:

The Hi-Force AHP range of Hydrotest pumps are supplied from a range of 8 models with output pressures ranging from 6 bar (87psi) to 2931bar (42,500psi) and are suitable for use with various fluids including water.



AHP58

2.0 Before operating your Hi-Force Hydraulic Power Pack please ensure that the following instructions are carried out.

1. Check that there is sufficient fluid in the reservoir. If not, top up with mains water or suitable hydraulic oil.
2. Check that the "Pressure Let-Down Valve" is in the open position (Turn anti-clockwise).
3. Close off the "Air Stop Valve". (Turn anti-clockwise).
4. Turn the "Air pressure Regulator" anti-clockwise until the handle becomes free and easy.
5. Connect a suitable air supply to the "Air Supply connection" (3/8" BSP Female).
Please note that the maximum air pressure supplied to the Power Pack should never exceed 100 PSI.
6. Connect a suitable hydraulic hose (rigid piping with screwed and coned connections in case of very high pressure Power Packs) to the outlet connection. Please note that the hydraulic hose or piping together with adapters and couplings should have a rated working pressure equal to the maximum output pressure of the Power Pack.

Hoses are available from Hi-Force Ltd or your Hi-Force Distributor suitable for working pressures up to 30,000 PSI. Above this pressure, stainless steel piping together with high-pressure fittings should be used. These are also available from Hi-Force.

INSTRUCTION MANUAL – AIR DRIVEN HYDROTEST PUMPS:

Model Series: AHP10, AHP26, AHP36, AHP58, AHP107, AHP187, AHP275, AHP425, AHP2-036, AHP2-060, AHP2-097, AHP2-144, AHP2-237, AHP3-040, AHP3-060, AHP3-100, ATDP63, ATDP125, ATDP216,

Once the above instructions have been

completed the Power Pack is ready for use and the following operating procedure can be followed:-

1. Open the Air Stop Valve (2) (turn clockwise) **SEE FIGURE 1**.
2. Turn the Air Pressure Regulator (1) slowly clockwise until the pump begins to reciprocate. The pump should start on 10 to 15 PSI of air under normal conditions.
3. Turn the Air Pressure Regulator (1) clockwise further until 25 to 30 PSI is reached on the Air Pressure Gauge (4), and then allow the pump to run until all air has been purged from the circuit. Please note that when pressure testing large vessels and pipes, care should be taken to bleed off any air within the object being tested.
4. Turn the Air Pressure Regulator (1) anti-clockwise until zero pressure is reached on the Air Pressure Gauge (4).
5. Close the Pressure Let-Down Valve (3) (Turn clockwise).
6. Close any further "Air Vent" valves, external to the Power Pack once all air has been purged from the total system.
7. Turn the Air Pressure Regulator (1) slowly clockwise until the desired hydraulic pressure is reached on the High Pressure Gauge (5)

Note

If the object being tested is large it will take a while before the pressure builds up in the system and registers on the high pressure gauge. Care should be taken not to set the air driving pressure too high whilst being unattended as this may lead to the object under test being over pressurised.

The air drive pressure can be pre-set if desired by closing off the air stop valve prior to use and winding the air pressure regulating valve clockwise until the required air pressure is registered on the air pressure gauge.

The air pressure should ideally be set slightly below that desired so that it can be raised to the correct amount once the output pressure has built up and the pump has stalled out.

The pump can then be started and stopped by using the air stop valve only if preferred.

Once set the pump will maintain the set pressure indefinitely and make up any fluid losses within the hydraulic system automatically.

To let down pressure

1. Close off the Air Stop Valve (2) (Turn anti-clockwise).

2. Turn the Air Pressure Regulator (1) anti-clockwise until the Air Pressure Gauge (4) is reading zero pressure.
3. Open slowly the Pressure Let-Down Valve (3) (Turn anti-clockwise) until the high-pressure gauge reads zero.
4. Disconnect the hydraulic hose from the high-pressure outlet connection.
5. Disconnect the air supply from the "Air Supply Connection".

Figure 1



AHP2 SERIES – Hydrotest Pumps:

1.0 General Description:

The Hi-Force AHP2 range of Hydrotest pumps are supplied from a range of 5 models with output pressures ranging from 17 bar (246psi) to 1634bar (23700psi) and are suitable for use with various fluids including water.



2.0 Before operating your Hi-Force Hydraulic Power Pack please ensure that the following instructions are carried out.

1. Check that there is sufficient fluid in the reservoir. If not, top up with mains water or suitable hydraulic oil.
2. Check that the "Pressure Let-Down Valve" is in the open position (Turn anti-clockwise).

Hi-Force Limited – Prospect Way – Daventry – Northants NN11 8PL – United Kingdom

Tel: +44(0) 1327 301000: Fax: +44(0) 1327 706555: Website: www.hi-force.com

INSTRUCTION MANUAL – AIR DRIVEN HYDROTEST PUMPS:

Model Series: AHP10, AHP26, AHP36, AHP58, AHP107, AHP187, AHP275, AHP425, AHP2-036, AHP2-060, AHP2-097, AHP2-144, AHP2-237, AHP3-040, AHP3-060, AHP3-100, ATDP63, ATDP125, ATDP216,

3. Close off the "Air Stop Valve". (Turn anti-clockwise).
4. Turn the "Air pressure Regulator" anti-clockwise until the handle becomes free and easy.
5. Connect a suitable air supply to the "Air Supply connection" (3/8" BSP Female).
Please note that the maximum air pressure supplied to the Power Pack should never exceed 100 PSI.
6. Connect a suitable hydraulic hose (rigid piping with screwed and coned connections in case of very high pressure Power Packs) to the outlet connection. Please note that the hydraulic hose or piping together with adapters and couplings should have a rated working pressure equal to the maximum output pressure of the Power Pack.

Hoses are available from Hi-Force Ltd or your Hi-Force Distributor suitable for working pressures up to 30,000 PSI. Above this pressure, stainless steel piping together with high-pressure fittings should be used. These are also available from Hi-Force.

Once the above instructions have been

completed the Power Pack is ready for use and the following operating procedure can be followed:-

1. Open the Air Stop Valve (2) (turn clockwise) **SEE FIGURE 1.**
2. Turn the Air Pressure Regulator (1) slowly clockwise until the pump begins to reciprocate. The pump should start on 10 to 15 PSI of air under normal conditions.
3. Turn the Air Pressure Regulator (1) clockwise further until 30 to 40 PSI is reached on the Air Pressure Gauge (4), and then allow the pump to run until all air has been purged from the circuit. Please note that when pressure testing large vessels and pipes, care should be taken to bleed off any air within the object being tested.
4. Turn the Air Pressure Regulator (1) anti-clockwise until zero pressure is reached on the Air Pressure Gauge (4).
5. Close the Pressure Let-Down Valve (3) (Turn clockwise).
6. Close any further "Air Vent" valves, external to the Power Pack once all air has been purged from the total system.

7. Turn the Air Pressure Regulator (1) slowly clockwise until the desired hydraulic pressure is reached on the High Pressure Gauge (5)

Note

If the object being tested is large it will take a while before the pressure builds up in the system and registers on the high pressure gauge. Care should be taken not to set the air driving pressure too high whilst being unattended as this may lead to the object under test being over pressurised.

The air drive pressure can be pre-set if desired by closing off the air stop valve prior to use and winding the air pressure regulating valve clockwise until the required air pressure is registered on the air pressure gauge.

The air pressure should ideally be set slightly below that desired so that it can be raised to the correct amount once the output pressure has built up and the pump has stalled out. The pump can then be started and stopped by using the air stop valve only if preferred.

Once set the pump will maintain the set pressure indefinitely and make up any fluid losses within the hydraulic system automatically.

To let down pressure

1. Close off the Air Stop Valve (2) (Turn anti-clockwise).
2. Turn the Air Pressure Regulator (1) anti-clockwise until the Air Pressure Gauge (4) is reading zero pressure.
3. Open slowly the Pressure Let-Down Valve (3) (Turn anti-clockwise) until the high-pressure gauge reads zero.
4. Disconnect the hydraulic hose from the high-pressure outlet connection.
5. Disconnect the air supply from the "Air Supply Connection".

Figure 1



INSTRUCTION MANUAL – AIR DRIVEN HYDROTEST PUMPS:

Model Series: AHP10, AHP26, AHP36, AHP58, AHP107, AHP187, AHP275, AHP425, AHP2-036, AHP2-060, AHP2-097, AHP2-144, AHP2-237, AHP3-040, AHP3-060, AHP3-100, ATDP63, ATDP125, ATDP216,

AHP3 SERIES – Hydrotest Pumps:

1.0 General Description

The Hi-Force AHP3 range of Hydrotest pumps are supplied in a range of 3 models with output pressures ranging from 42 bar (609psi) to 700bar (10000psi) and are suitable for use with various fluids including water.



2.0 Before operating your Hi-Force Hydraulic Power Pack please ensure that the following instructions are carried out.

1. Connect the liquid supply to the pump inlet port (1 ¼" NPT.) This is normally from a reservoir tank.
2. Ensure that the liquid is filtered before reaching the pump unit liquid inlet port.
3. Hydraulic oil (ISO 10 or 32) or water can be used. When using water, a Glycol additive to the water will reduce seal wear in the unit.
4. Check the air lubricator bottle is filled (use any light grade lubricating oil –SAE 15). To top up undo the screw on top of the bottle and top up.

(Important Safety note: Ensure the air supply is disconnected when filling the bottle.)

5. The lubricator is factory set to deliver 1 drop every 25 strokes of the pump. The red knob is used to affect this setting.
6. Connect the air supply line to the pump inlet (1/2" BSP) Min recommended pipe size ½ bore. Air requirement is 70-100psi, 56 S.C.F.M. Ensure the air on/off valve is closed.
7. The item requiring hydraulic pressure connection may now be connected to the outlet block. ½" NPTF

NB use only fittings and tubing, suitable for the maximum pressure performance of the pump.

Once the above instructions have been completed the Power Pack is ready for use and the following operating procedure can be followed:-

1. Make sure the Isolator valve and pressure let down valve is open and the air pressure regulator is turned fully anticlockwise. Direct the drain hose into a suitable location as fluid will be

discharged from this once the pump starts.

2. Open the air on/off valve and turn the regulator clockwise until the pump starts to cycle. Increase the air pressure until the pump is running at around 100 cycles per minute. Allow the pump to cycle for approximately two minutes, this will purge the pump of any air.
3. **NB: This will not normally purge air from the item under test. Additional vent points (or other precautions) will be required to ensure the item under test is completely filled with liquid before pressurisation otherwise a dangerous situation may occur.**
4. Stop the pump by closing the air on/off valve. Should any black oil be visible around the pump air motor exhaust, this should not give rise to concern, as lubricated air is fed to the pump, and excess oil will be discarded via the exhaust.

To apply hydraulic pressure:-

5. Close the pressure let down valve.
6. Make sure the isolation valve is open.
7. Turn the air pressure regulator valve fully anticlockwise.
8. Open the air ON/OFF valve and gradually increase air pressure by turning the pressure-regulator clockwise until the pump starts to cycle. This will deliver liquid to the item under test and (once all vent ports are closed) allow hydraulic pressure to build up. The pressure may build up very slowly depending on the size of the item under test. This pressure will be indicated on the large pressure gauge.
9. The hydraulic output pressure is directly proportional to the air inlet pressure. The pump will stall when the hydraulic pressure reaches a balance point directly related to the air pressure setting. To increase the hydraulic pressure further, the air pressure must be increased.
10. This feature can be used to maintain pressure in a vessel over a period of time. The pump will cycle occasionally to keep the pressure topped up against slight leakage loss.

INSTRUCTION MANUAL – AIR DRIVEN HYDROTEST PUMPS:

Model Series: AHP10, AHP26, AHP36, AHP58, AHP107, AHP187, AHP275, AHP425, AHP2-036, AHP2-060, AHP2-097, AHP2-144, AHP2-237, AHP3-040, AHP3-060, AHP3-100, ATDP63, ATDP125, ATDP216,

11. The Isolation valve may be closed if desired to maintain pressure in the item under test, but it must be remembered that if this is done, the pump will not automatically keep the pressure topped up.

To release hydraulic pressure:

Make sure the drain hose is directed into a suitable container or back to the reservoir and open the pressure let down valve. Liquid will be discharged along the drain hose.

When releasing hydraulic pressure, it is important to do so slowly to prevent possible damage to the hydraulic pressure gauge.

TROUBLE SHOOTING GUIDE ALL AHP MODELS.

Pump will not start:

- Check the mains air supply.
- Check the regulated air pressure is available via the air pressure gauge, mounted on the air regulator.
- Check the air valve is turned ON.
- If the pump will still not actuate it will require inspection.

Pump will not build up pressure:

- Insufficient air pressure causing the pump to stall.
- Pressure release valve, not closed. Close to build up pressure.
- Insufficient hydraulic fluid, available from the reservoir.
- Tube connections loose in system, check and rectify.
- Strainer in pump suction blocked, check and clean if necessary.
- Loss of pressure may also be caused by one of two reasons, the hydraulic check valves have developed a leak, or the fluid is bleeding past the seals in the hydraulic cylinder. Get the unit serviced or repaired.

Pump not running properly:

- If the pump appears to be short stroking and running too fast without pumping properly, it usually indicates that the air check assembly is not working as it should be. Get the unit repaired/serviced.
- Should the pump commence to run erratically and in a jerky manner after a period of time it is usually an indication that a seizing action is taking place in the hydraulic piston/cylinder assembly. Foreign matter such as dirt, grit or chemicals that do not have sufficient

lubrication qualities being present in the fluid supply usually causes this. If the hydraulic piston and cylinder have not been damaged a thorough cleaning will normally solve this. The unit may require service or repair.

- For maximum volume of flow, make sure that a sufficient flow of air is supplied to the pump. Using a smaller pipe than the "Air In" port of the pump will not allow it to run at its full rated capacity. Long runs of relatively small pipe supplying air to the pump will have the same effect.
- If an excessive amount of oil or water is coming through the pump air exhaust, check the following.
 - A) The lubricating unit on the air supply is delivering too much oil. Adjust to about one drop of oil for every 20 strokes of the pump.
 - B) The filtering unit in the air supply is not functioning correctly. The bowl should be cleaned periodically to ensure delivery of clean air to the pump.
 - C) The fluid being pumped may be leaking past the seals in the hydraulic cylinder into the air motor. The unit will require inspection and repair.

SERVICING

The pack is designed for long and trouble free service, in a rugged environment with a minimum of servicing. Regular servicing is confined to:

- Topping up the air lubricator.
- Regular draining of the air filter bowl.
- Occasional cleaning of the air filter bowl using warm soapy water only.

! WARNING: shut off the air supply before removing the air filter bowl.

General Arrangement of Pump unit:

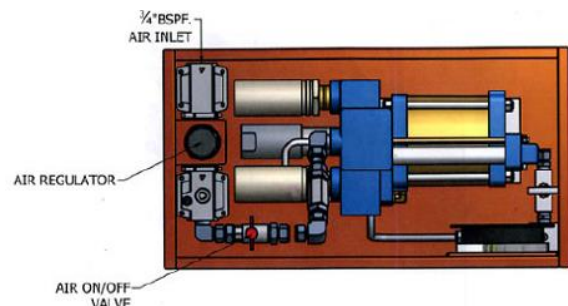

INSTRUCTION MANUAL – AIR DRIVEN HYDROTEST PUMPS:

Model Series: AHP10, AHP26, AHP36, AHP58, AHP107, AHP187, AHP275, AHP425, AHP2-036, AHP2-060, AHP2-097, AHP2-144, AHP2-237, AHP3-040, AHP3-060, AHP3-100, ATDP63, ATDP125, ATDP216.

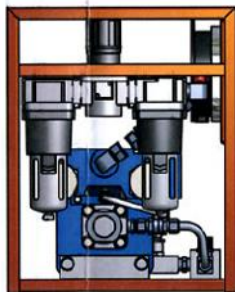
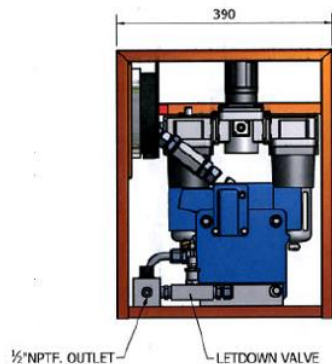
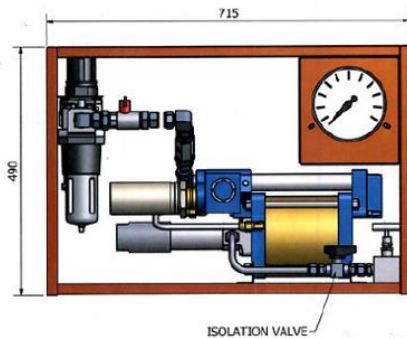

ATDP SERIES – Hydrotest Pumps:

1.0 General Description

The Hi-Force ADTP range of Hydrotest pumps are supplied in a range of 3 models with output pressures ranging from 87 bar (1260psi) to 1489bar (21600psi) and are suitable for use with various fluids.

The ADTP air driven liquid pump range work on an automatic reciprocating differential area piston principle that uses large area air drive pistons connected to smaller area hydraulic pistons to convert compressed air power into hydraulic power.

The ADTP pump range has a double acting motion incorporating two hydraulic cylinder and

piston assemblies, as liquid is introduced into one hydraulic cylinder on the pump suction stroke, liquid is automatically delivered from the second high pressure cylinder at the same time on the pump delivery stroke and vice versa. When the pump reaches the end of its stroke the spool valve in the air change over valve motor automatically shifts, reversing the pump direction; hence delivery flow is relatively smooth with only a small interruption in flow (dwell) as the pump air pistons change direction.

The units consist of a robust framework painted to Hi-Force standard colour, fitted with an air driven hydraulic pump and complete with all necessary hydraulic accessories i.e. a 150mm diameter hydraulic pressure gauge, a hydraulic pressure release valve and all interconnecting pipe-work fittings and adaptors, terminating at a single high pressure outlet connection port. Pneumatic accessories include an air filter, air pressure regulating valve, oil lubricator, air gauge and air on/off valve.

A fluid inlet connection is provided and a Y type fluid strainer and fluid relief valve set at approximately 10 bar is fitted between this connection and the pump inlet check valves.

Provision is provided for fluid drainage via a nylon hose connected to the hydraulic pressure release valve.

The ATDP63 has a maximum recommended working pressure of **434Bar (6,295psi)** on the hydraulic pressure circuit.

The hydraulic pressure to be generated by the air driven pump is dependent upon the air pressure applied i.e.

Pump ratio **63/1**: 1psig air drive pressure applied can generate 63psig hydraulic pressure.

The ATDP125 has a maximum recommended working pressure of **862Bar (12502psi)** on the hydraulic pressure circuit.

The hydraulic pressure to be generated by the air driven pump is dependent upon the air pressure applied i.e.

Pump ratio **125/1**: 1psig air drive pressure applied can generate 125psig hydraulic pressure.

The ATDP216 has a maximum recommended working pressure of **1489Bar (21596psi)** on the hydraulic pressure circuit.

INSTRUCTION MANUAL – AIR DRIVEN HYDROTEST PUMPS:

Model Series: AHP10.AHP26, AHP36, AHP58, AHP107, AHP187, AHP275, AHP425, AHP2-036, AHP2-060, AHP2-097, AHP2-144, AHP2-237, AHP3-040, AHP3-060, AHP3-100, ATDP63 ATDP125, ATDP216,

The hydraulic pressure to be generated by the air driven pump is dependent upon the air pressure applied i.e.

Pump ratio **216/1**: 1psig air drive pressure applied can generate 216psig hydraulic pressure.

PREPARATION FOR USE.

It is recommended to use good quality clean & dry air (without moisture content) to drive the air driven pump unit. As the air pressure drops at the pump exhaust ports, the air will cool and any water droplets in the air can freeze prematurely due to temperature variation. For this reason we include and recommend the use of 'Killfrost' at all times to be placed in the installed pump oil lubrication bottle. The lubricator bottle drop feed rate is advised at 1 drop per 20 pump strokes.

If for any reason the lubricator is not used, the air motor should be disassembled, inspected and repacked with suitable compound grease every 1 million strokes. Silicone type grease is prone to stiffening when not in use, at a minimum the grease should be changed after a 6month idle period and every 12 months in a scheduled routine service interval at a minimum.

Connect the hydraulic pressure outlet port to the equipment to be pressurised via a flexible hose assembly or via a rigid pipe-work system. Ensure that all attached hose, pipe-work and fittings are rated suitably to match, at a minimum, or exceed the maximum working pressure rating of the pump unit.

Direct the provided drain hose into a suitable container or drain.

Connect a 1" bore air supply hose to the power pack air inlet port. Use appropriately pressure rated air hose and fittings for this purpose, these components must be rated at a higher working pressure than the maximum supply air pressure that can be applied to the power pack. (1/2" bore air supply tubing is the smallest size that will allow the pump to operate).

Ensure that the air on/off valve on the pump is in the closed before switching on the air supply. (Note: To achieve the potential maximum working pressure and output flow capability, ensure an air supply of 7 bar (100psi) is available with a flow rate of 212 SCFM (6M³/min). The use of a smaller bore air hose or a smaller SCFM volume supply is acceptable but will diminish the maximum potential flow-rate from the pump.

Make connections to the fluid inlet port using suitably rated hose, pipe-work and fittings and a fluid isolation valve. The fluid inlet hose and fittings bore is recommended to be not less than 1" bore.

(Once the pump has raised hydraulic pressure DO NOT close the fluid inlet isolation valve).

Ensure the water supply is sufficient and only at 7 bar maximum pressure. It is advisable to ensure clean water (fluid) is used as this prevents any possible chance of debris contaminating the pump check valves (Y type strainer filter built in pump unit water line).

If fluid is being supplied from a tank ensure the tank is sited close to the fluid inlet port on the power pack or sited above the level of the fluid inlet port (positive head/displacement pump).

Reducing the fluid supply inlet hose/pipe bore or supplying water from a tank at a lower level than the pump inlet port may cause pump cavitation's and potential damage, so should always be avoided. DO NOT run the pump dry, as this will damage the hydraulic components.

PRINCIPLE STEPS OF OPERATION

1) Check that the pump on/off air valve is closed, and that the hydraulic pressure release valve is in the open position.

2) Adjust the pump air pressure-regulating valve anticlockwise until it is fully wound out. Switch on the air supply to the pump by external means.

3) Plug the hydraulic outlet connection.

4) Turn on the water supply to the pump. As long as the water supply is above approximately 0.7bar (10 psi) the water will flow through the pump and through the drain hose attached to the pressure release valve, bleeding the system. If not (flowing water) turn the pump air pressure-regulating valve slowly clockwise until 15-20 psi is shown on the air pressure regulators own air pressure gauge, the pump will operate pumping the inlet water supply to drain.

5) Turn the pump air on/off valve to the off position and close the hydraulic pressure release valve once any air bubbles, seen in the nylon drain hose, have disappeared and the system is bled properly.

6) To use the pump:

Open the pump air on/off valve.

INSTRUCTION MANUAL – AIR DRIVEN HYDROTEST PUMPS:

Model Series: AHP10.AHP26, AHP36, AHP58, AHP107, AHP187, AHP275, AHP425, AHP2-036, AHP2-060, AHP2-097, AHP2-144, AHP2-237, AHP3-040, AHP3-060, AHP3-100, ATDP63 ATDP125, ATDP216,

Slowly adjust the pump air pressure-regulating valve clockwise, the pump will reciprocate and start to displace fluid into the system and build up pressure, the pressure generated can be viewed on the hydraulic pressure gauge.

The maximum pressure achievable at various air pressures can be seen on the ATDP brochure page under the heading "Max-output pressure at airline input pressure" e.g. **ATDP63** if 80 psi air pressure is applied then the maximum pressure the pump can generate is approximately $80\text{psi} \times \frac{63}{1} = 5,040\text{psi}$ (347bar). **ATDP125** if 80 psi air pressure is applied then the maximum pressure the pump can generate is approximately $80\text{psi} \times \frac{125}{1} = 10,000\text{psi}$ (700bar). **ATDP216** if 80 psi air pressure is applied then the maximum pressure the pump can generate is approximately $80\text{psi} \times \frac{216}{1} = 17280\text{psi}$ (1191bar).

If a slower pump cycle rate is required the drive air pressure can be reduced by turning the air pressure regulating valve anticlockwise and/or by partially closing the pump air on /off valve

The pump can operate as a transfer pump filling the vessel under test with liquid.

The pump will gradually and naturally start to cycle at a slower rate as the pressure in the vessel under test increases until it stops (stalls) when a balance of forces is reached i.e. when the air drive pressure x air drive piston area = stall pressure x driven hydraulic piston area.

The pump will hold pressure indefinitely unless a leak occurs, at which time the pump will automatically cut in once the leak rate reaches a certain level to try to maintain the pressure in the system.

If the air supply is turned to the OFF position the hydraulic pressure generated will hold on the pumps integral check valves (in small volume systems the hydraulic pressure may fall slightly and then stop whilst the check valve balls reseal, this is normal).

The pump will continuously stroke if the circuit is open (flushing mode).

Close the air start/stop valve to stop the pump at any point, if required.

Once the test is completed to release hydraulic system pressure:

Turn the air on/off valve to the off position

Turn the air pressure- regulating valve anticlockwise until it fully is wound out

Slowly open the pressure release valve and fluid will return via the drain hose to drain until zero pressure is indicated on the pump hydraulic pressure gauge.

It is possible to pre-set the pump so it stalls automatically at the desired pressure. This can be done by plugging the pressure outlet port and operating the pump. Adjust the air pressure regulator gradually upwards such that the pump stalls at the correct pressure. Release the pressure by opening the pressure release valve. Close the pressure release valve once more to check the set pressure. Provided that no adjustments are made the pump will repeat this set pressure when connected to a pressure vessel.

FAULT FINDING

ALL NORMAL RECOMMENDED SAFETY PRECAUTIONS SHOULD BE TAKEN WHEN PERFORMING MAINTENANCE ON HYDRAULIC AND PNEUMATIC EQUIPMENT.

1. PUMP NOT RUNNING PROPERLY OR ERRATICALLY OR STOPS OPERATING
 - (a) Pump mufflers beginning to block with ice or iced up.
 - (b) Pump fluid supply starved causing cavitations or irregular pumping action
 - (c) Pump air changeover valve sticking or pump external air pilot switches not engaging properly
 - (d) Insufficient lubrication
 - (e) Air supply starved
 - (f) Dirty air supply
2. LOSS OF HYDRAULIC PRESSURE
 - (a) Insufficient fluid supply
 - (b) Hydraulic check valves in pump leaking
 - (c) Hydraulic fluid leaking past seals in pump (Fluid can be seen leaking from the vent hole under one or each hydraulic cylinder).
 - (d) Leak from pipe- work
 - (e) Hydraulic pressure release valve leaking back to drain or left partially open accidentally

INSTRUCTION MANUAL – AIR DRIVEN HYDROTEST PUMPS:

Model Series: AHP10, AHP26, AHP36, AHP58, AHP107, AHP187, AHP275, AHP425, AHP2-036, AHP2-060, AHP2-097, AHP2-144, AHP2-237, AHP3-040, AHP3-060, AHP3-100, ATDP63, ATDP125, ATDP216,

General Arrangement of ATDP Pump Range.

PNEUMATIC AND HYDRAULIC CIRCUIT

