

Prepared by:-	Matthew Hughes	Approved by:-	Mark Dalley	Date: 22/01/13
REV NO:-	001			
ECO:-	4025			

The Hi-Force HMNS range of hydraulic nut splitters offers a choice of 3 models suitable for hexagon nut AF sizes from 17 to 50mm (M10 to M33 bolt sizes). The nut splitters are designed to easily split corroded nuts up to RC44 hardness, Hi-Force nut splitters offer the ideal 'cold cut' solution for removing worn or corroded fasteners, especially in applications where 'hot work' permits are not allowed

Before operating your Hi-Force HMNS series nut splitter check in the table below for the correct capacity to suit the nuts to be cut.

MODEL NO.	HEX SIZES (mm)	THREAD SIZES (mm)
HMNS 104	17-32	M10-M22
HMNS 110	32-41	M22-M27
HMNS 200	41-50	M27-M33

SAFETY

**READ THESE INSTRUCTIONS AND SAFETY WARNINGS FULLY
FAILURE TO DO SO COULD RESULT IN DEATH, PERSONAL
INJURY OR EQUIPMENT DAMAGE**

TAKE CARE WHEN OPERATING NUTSPLITTERS TO ENSURE THAT ALL BODILY PARTS ARE CLEAR OF THE CUTTING AREA.

ALWAYS WEAR SUITABLE EYE PROTECTION AS SPLINTERS MAY FLY.

GLOVES AND SAFETY FOOTWEAR ARE ALSO ADVISABLE.

DO NOT ATTEMPT TO CARRY THE NUTSPLITTER BY THE OPERATING LEVER

Fig 1

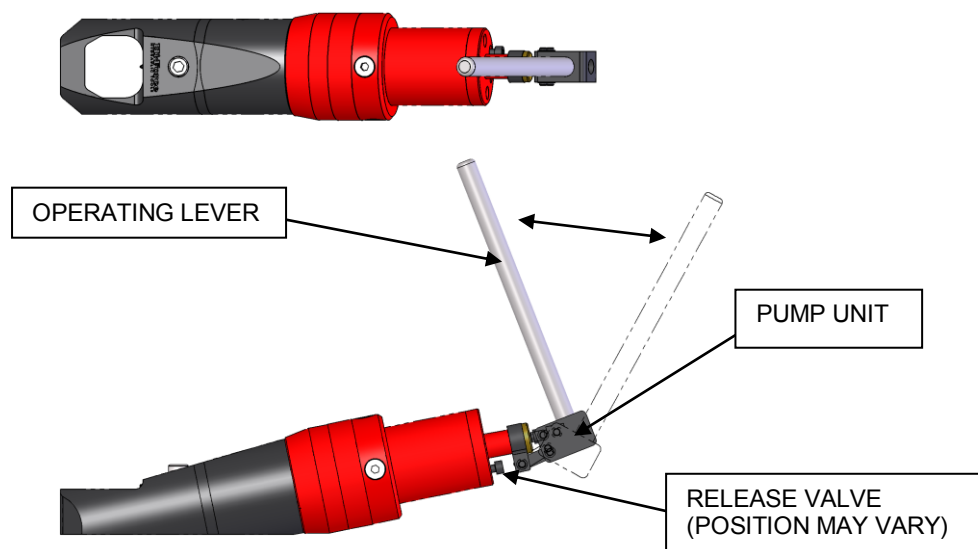

Prepared by:-	Matthew Hughes	Approved by:-	Mark Dalley	Date: 22/01/13
REV NO:-	001			
ECO:-	4025			

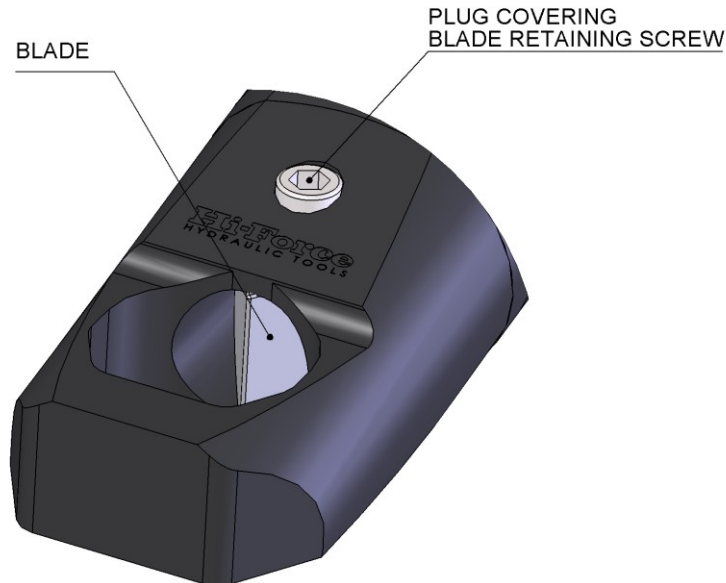
Fig 2

OPERATION

Using the slotted end of the operating lever, slacken the release valve (Fig 1) to ensure the blade is fully retracted. Tighten the release valve – do not use excessive force.

Fit the operating lever to the pump unit (Fig 1), ensuring it is pushed fully on.

Place the nut splitter over the nut to be cut so that the blade is aligned with the centre of one flat of the nut. Never try to cut on a corner of the nut. Operate the pump unit by operating the lever (Fig1) whilst holding the nut splitter in position. Stop the pump when the nut is cut through to avoid damage to the bolt. Retract the blade by opening the release valve (Fig 1).

If the nut cannot be removed after one cutting operation, reposition the nut splitter 180° from the first cut and make a second cut (Fig 3).

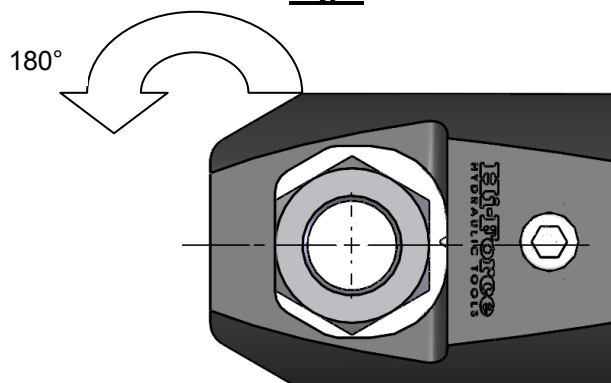
Fig 3

		OPERATING AND MAINTENANCE INSTRUCTIONS HYDRAULIC NUT SPLITTERS - HMNS RANGE		TDS:- 1388
Prepared by:-	Matthew Hughes	Approved by:-	Mark Dalley	Date: 22/01/13
REV NO:-	001			
ECO:-	4025			

CARE AND MAINTENANCE

After completing each cutting operation **ALWAYS** clean any debris from around the cutting blade and cutter jaw. This will greatly reduce the possibility of blade jamming.

After a period of operation, depending on the material being cut, the Blade may develop a slight 'Roll Burr' along the cutting edge. This 'Roll Burr' can be easily removed by using a knife sharpening stone, which should always be applied to the **FLAT SIDES** of the Blade.

Nut splitter blades can be replaced by firstly retracting the blade fully and removing the plug in the top of the nut splitter body (Fig 2). This provides access to the blade retaining screw, which can then be loosened, and the blade pulled from the end of the piston. Care should be taken when carrying out this operation to prevent injury from the blade particularly when fitting a replacement. Refitting is the reverse procedure taking care to ensure the blade retaining screw is correctly tightened. **THIS OPERATION SHOULD BE CARRIED OUT WITH THE RELEASE VALVE FULLY OPEN.**

Always use genuine Hi-Force hydraulic oil. The use of other fluids may invalidate your warranty.

After use, always fully retract the tool.

Protect tools from the elements when not in use. If storing for prolonged periods, grease exposed metal parts. **Never** store the tool with the blade extended.

To protect your warranty, have your cylinder serviced and repaired by an authorised Hi-Force repairer. Only use genuine Hi-Force spare parts. Spare parts sheets can be downloaded from our website www.hi-force.com.

Prepared by:-	Matthew Hughes	Approved by:-	Mark Dalley	Date: 22/01/13
REV NO:-	001			
ECO:-	4025			

UK Head Office:

**Hi-Force Limited
Prospect Way
Daventry
Northamptonshire
NN11 8PL
United Kingdom**

**Tel: + 44 1327 301000
Fax: + 44 1327 706555
Email: daventry@hi-force.com**

Hi-Force Regional Offices:

**Hi-Force Australia Pty. Ltd
Rockingham
Australia
Tel: +61 8 9591 1288
Email: australia@hi-force.com**

**Hi-Force Caspian
Baku
Azerbaijan
Tel: +994 12 447 4100
Email: baku@hi-force.com**

**Hi-Force Hydraulics (Asia) S.B
Selangor
Malaysia
Tel: +603 5569 4209
Email: malaysia@hi-force.com**

**Hi-Force Nederland BV
Strijen
Netherlands
Tel: +31 78 6745488
Email: holland@hi-force.com**

**Hi-Force Hydraulics (Pty) Ltd
Midrand
South Africa
Tel: +27 11 314 0555
Email: south.africa@hi-force.com**

**Hi-Force FZCO
Dubai
United Arab Emirates
Tel: +971 4 815 0600
Email: dubai@hi-force.com**

**Hi-Force Hydraulics
Abu Dhabi
United Arab Emirates
Tel: +971 2 551 3100
Email: abu.dhabi@hi-force.com**

**Hi-Force Hydraulic Equipment
(Shanghai) Ltd. Co.
Shanghai, China
Tel: +86 21 6697 3010
Email: china@hi-force.com**

GLOBAL BRAND. LOCAL SERVICE.**www.hi-force.com**