

Prepared by:-	M.Davies	Approved by:-		Date: 10/09/14
REV NO:-	1			
ECO:-	4282			

## **INTRODUCTION**

The SC30/ SC40 self-contained hydraulic cable crimping tools are fitted with an automatic pressure relief valve and are supplied complete with standard die sets and carrying case. Models with 180° rotating head are designed for easy access into confined spaces.

- Models SC30 and SC40 are suitable for crimping connectors from 35 to 400mm<sup>2</sup>. They incorporate a 180° rotating head

## **SAFETY NOTES**

**WARNING:** All Hi-Force crimpers require a certain maximum handle force to produce the designed crimping force. **NEVER** use extensions or levers to exert more force than the maximum capacity detailed in your Hi-Force catalogue

Always wear suitable personal protection when operating hydraulic equipment.

**DANGER:** Keep all body parts away from Crimper and work piece during operation.

**IMPORTANT:** Ensure that the correct size tool and die is selected for the job.

**IMPORTANT:** Minimum age of operator must be 18 years. The operator must have read and understood all instructions, safety issues, cautions and warnings before starting to operate this equipment.

**WARNING:** Risk of finger trapping. Only hold the tool by means of the handle.

**WARNING:** Do not overload equipment. Overloading causes equipment failure and possible personal injury.

**CAUTION:** Make sure that all system components are protected from external sources of damage, such as excessive heat, flame, moving machine parts, sharp edges and corrosive chemicals.

**WARNING:** Immediately replace worn or damaged parts with genuine Hi-Force parts.

**WARNING:** Always wear safety glasses and other appropriate personal protection equipment. The operator must take precautions against injury due to failure of the tool or work piece.

## **SELECTION AND INSERTION OF DIE SETS**

All Hi-Force hydraulic crimpers are supplied complete with Die sets to suit the applicable range of the Crimper. All Die sets are marked with their applicable size capacity to avoid accidental mixing of different sizes.

1. To insert the Dies depress (or pull, depending on model) the locating button plunger on the head assembly to retract the locating plunger. Slide Die into position. Release locating plunger to 'Lock' in to the groove in the rear of the die. Repeat on opposite side of crimper. If required advance piston to expose Die release plunger. Check the Die is correctly located by trying to slide the Die out. It should not move! See Figure 1.

FIGURE 1

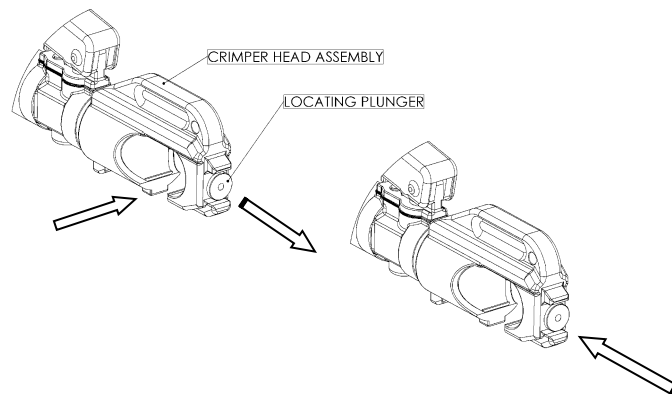

Prepared by:-	M.Davies	Approved by:-		Date: 10/09/14
REV NO:-	1			
ECO:-	4282			

2. Correctly position the crimper over the connector to be crimped. Commence pumping the handle to advance the Die, paying particular attention that the tool is square to the connector being crimped. See Figure 2.

FIGURE 2.

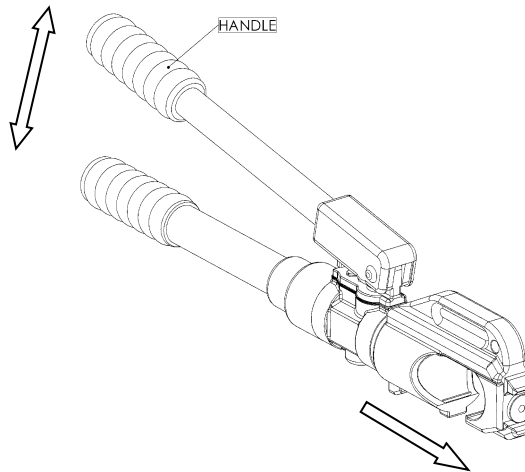

**Note:** The operator will need to continue to operate the Crimping tool handles until the two halves of the Die fully close and the pressure release mechanism 'clicks in'. At which time the lever action will seem lighter.

3. To retract the Die once they have fully closed around the connector, turn the pump handle through approximately 45° so that the handle is in-line with the Release Plunger. Then depress the handle to retract the Die.

See Figure 3.

FIGURE 3.

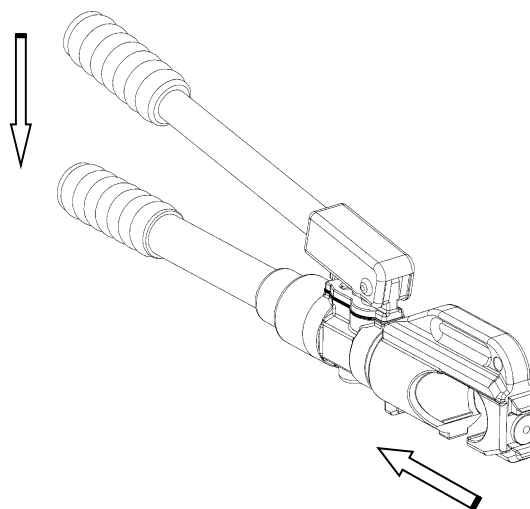

Prepared by:-	M.Davies	Approved by:-		Date: 10/09/14
REV NO:-	1			
ECO:-	4282			

**MAINTENANCE**

- Keep your Hi-Force crimper set free from dirt, sand and grease at all times. Any contamination will greatly reduce the Crimper effectiveness. Crimpers come complete with either storage boxes or bags. Always store your Hi-Force Crimper Set properly.
- Regularly check all fastenings to ensure they have not worked loose.
- Always fully retract the Crimper Head Piston between operations and while stored. Leaving the Piston extended will weaken the Retraction Spring and also leave the piston exposed to damage/ corrosion.
- For major overhauls/ repairs contact HI-Force or your nearest Hi-Force service centre.

Prepared by:-	M.Davies	Approved by:-		Date: 10/09/14
REV NO:-	1			
ECO:-	4282			

**UK Head Office:**  
**Hi-Force Limited**  
**Prospect Way**  
**Daventry**  
**Northamptonshire**  
**NN11 8PL**  
**United Kingdom**

**Tel: + 44 1327 301000**

**Fax: + 44 1327 706555**

**Email: [daventry@hi-force.com](mailto:daventry@hi-force.com)**

**Hi-Force Regional Offices:**

**Hi-Force Australia Pty. Ltd**  
**Rockingham**  
**Australia**  
**Tel: +61 8 9591 1288**  
**Email: [australia@hi-force.com](mailto:australia@hi-force.com)**

**Hi-Force Caspian**  
**Baku**  
**Azerbaijan**  
**Tel: +994 12 447 4100**  
**Email: [baku@hi-force.com](mailto:baku@hi-force.com)**

**Hi-Force Hydraulics (Asia) S.B**  
**Selangor**  
**Malaysia**  
**Tel: +603 5569 4209**  
**Email: [malaysia@hi-force.com](mailto:malaysia@hi-force.com)**

**Hi-Force Nederland BV**  
**Strijen**  
**Netherlands**  
**Tel: +31 78 6745488**  
**Email: [holland@hi-force.com](mailto:holland@hi-force.com)**

**Hi-Force Hydraulics (Pty) Ltd**  
**Midrand**  
**South Africa**  
**Tel: +27 11 314 0555**  
**Email: [south.africa@hi-force.com](mailto:south.africa@hi-force.com)**

**Hi-Force FZCO**  
**Dubai**  
**United Arab Emirates**  
**Tel: +971 4 815 0600**  
**Email: [dubai@hi-force.com](mailto:dubai@hi-force.com)**

**Hi-Force Hydraulics**  
**Abu Dhabi**  
**United Arab Emirates**  
**Tel: +971 2 551 3100**  
**Email: [abu.dhabi@hi-force.com](mailto:abu.dhabi@hi-force.com)**

**Hi-Force Hydraulic Equipment**  
**(Shanghai) Ltd. Co.**  
**Shanghai, China**  
**Tel: +86 21 6697 3010**  
**Email: [china@hi-force.com](mailto:china@hi-force.com)**